



For Earth, For Life  
Kubota

CD

KUBOTA COMPACT DISC HARROW  
CD1000 - CD2000 SERIES

Optimum soil and residue incorporation



# UP TO 15% LIGHTER THAN THE CD2000

## KUBOTA CD1000 RIGID - FOLDABLE - TRAILED



*CD1000T trailed from 4.00m to 5.00m working width*

### **Ideal for reducing soil compaction**

The CD1000 series is a lighter execution of the CD2000 series for more shallow use from 2,5m to 5,0m mounted and from 4m to 5m trailed working width.

This machine is for farmers who want to use the compact disc harrow up to 10 cm deep. Consequently, the machine is 15% lighter on mounted version and 7% on trailed models, easier to lift, ideal for reducing soil compaction and more economic for farmers.

The frames have been designed to carry the heaviest roller like the Actipack.

A new disc arm is used that has the heat treated disc of 520 x 5 mm – (hardness 215kg/mm<sup>2</sup>). The arm cover avoids any lateral movement during work for a constant cutting quality.

This disc hub is maintenance-free and has a long life time under large pressure at high working speed.

The working depth is very easy to adjust by pivoting spacers according to the required depth. If the full roller weight is required, only one action on the hydraulic is necessary. Simple, friendly and efficient!

For a nice leveling on the edge, the soil flow is controlled by lateral deflectors. A finger harrow can be fitted in between to increase the residues incorporation.

The CD1000 range can be combined with SH200 or SH500 for establishing cover crops or grass in one pass during the stubbling action. A wide range of packer rollers is available.



*CD2000 rigid mounted frame from 2.50 to 4.00m working width*



*CD2000F mounted foldable from 4.00m to 5.00m working width*



*CD1500F: Transport width always below 2.50m ensure a safe road transport.*

# OPTIMUM INCORPORATION

## KUBOTA CD2000 RIGID - FOLDABLE - TRAILED



*CD2000T trailed from 4.00m to 5.00m working width*

### **Working quality, multifunctional and high output**

Stubble cultivation is of major importance within conservation tillage: It incorporates weed and volunteer cereal seeds into the soil with intensive mixing and promotes their germination for a more efficient subsequent treatment.

The even incorporation of the straw presents a key factor for seed germination. The CD2000 is ready for shallow as well

as for deeper cultivation and of course the mixing of the straw. It also shows excellent performance with large amounts of residue (straw, intermediate green crops, etc.) thanks to its 600mm discs.

The CD2000 convinces with good penetration, deeper cultivation and superb cutting quality, high output, simple adjustments and minimum maintenance costs.

The CD2000 is extremely sturdy as it is fitted with a frame of a well established quality and strength in the Kubota cultivator range. With a reinforced headstock and a frame size of 100×100×8mm, it can be equipped with the heaviest roller. The brackets of the roller are fixed at the front bar of the frame for a better weight transfer during road transport and also at higher driving speeds.

Even with a distance of 900mm between the disc sections, the CD2000 only requires low lifting capacity (2.74m of length).



*CD1000 rigid mounted frame from 2.50 to 4.00m working width*



*CD1000F mounted foldable from 4.00m to 5.00m working width*



*CD2500T: Road Transport – Simple and Safe, Despite the Size!*

# HIGH PERFORMANCE AND SAFE

## KUBOTA CD1000T AND CD2000T



### Semi-mounted trailed

Available in working widths of 4m to 5m, the semi-mounted CD1000T/CD2000T is ready for high performance.

Linked to the lifting arms, the CD1000T/CD2000T can be driven by medium-sized tractors even when equipped with the heaviest rollers like the Actipack.

The individual adjustments are easily done: all of them by hydraulic from the tractor cab (hydraulic/mechanic depth adjustment, folding/unfolding, lifting).

The strong carriage and a transport width of 2.75m for the CD2000T and 2.50m for CD1000T ensure a safe road transport.

NB: Both machines are homologated at 40km/h in Germany.

For additional stability on the road, the CD1000T/CD2000T is equipped with a hydraulic suspension as standard equipment.

The CD1000T/CD2000T can be fitted with several tyre sizes depending on the requirements:

400/60x15.5, 480/45x17 or 520/50x17.



# ROAD TRANSPORT



## Stable working position

For a large stability of the machine during operation, land wheels of 340/55x16 (option) ensure the depth control in front of the discs. Due to this close distance between the land wheels and the roller, the discs in front and at the rear work at a constant depth and prevent any lateral movement of the machine during operation.

The working depth can be easily adjusted by spacers at the depth cylinders as with the rollers.

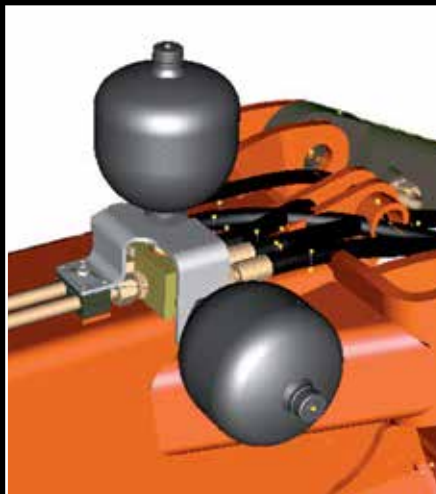

## High stability during work

The CD1000T and CD2000T are extremely stable as they are equipped with a double suspension device that protects the frame against stress and increase tremendously the stability of the machine during work. In addition, both models can be equipped with front gage wheels to improve the stability even further.

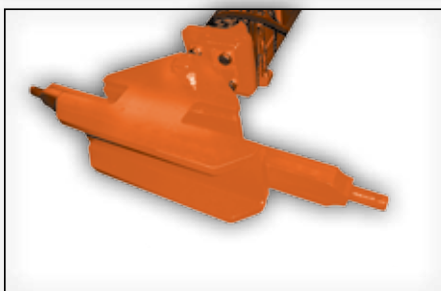

### Cross shaft Cat. III

The crossshaft allows an angle of steering lock of up to 180° for an excellent manoeuvrability.

- For tractors with twin or wide wheels, the CD1000T/CD2000T can have a drawbar extension of 85cm to ensure short turns in headlands. (NB: not homologated in France and Germany)
- Machines equipped without cross-shaft must have the parallel lifting



### Fix pulling eye ø50mm

It is used to link the Qualidics to a fixed hitch.



### Pivoting pulling eye ø 50mm

It is used on fixed hitch and allow to work in hilly conditions up to +/- 14°.

# UNIQUE FEATURES



CD2000 series



CD1000 series

## Robust Disc Arms, Maintenance-free, High Capacity Bearings and Large Conical Discs.

### CD2000 series

#### A light and strong arm

The unique design feature allows for a reduction in weight and an increase in strength. The hollow design also ensures the arm can withstand high front and lateral loads and the special profile provides good soil flow even with larger volumes of plant residues.

#### Perfect cutting angle

The upper part of the arm is fitted with special brackets to avoid any lateral movement: the cutting angle is fixed to ensure an optimum cutting quality even under the driest of conditions. The rear disc section operates offset to the front unit to provide optimum performance and trash incorporation.

#### A rubber shock system adjusted to the size of the disc and working speed

The rubber buffers absorb any shock loads from contact with unforeseen obstacles. If the forces become too high, the disc arms will rotate to overcome the obstacle thus protecting the implement.

### CD1000 series

#### Smaller specification but also strong!

The CD1000 series disc arm gets a special profile which has been performed by FEM (Finite Element Method) calculation. It allows high stress (lateral or radial) at high speed. The lighter disc arm version has been developed for the CD1000 in relation to the smaller disc diameter. But this new feature gets the same release force than the big version to ensure the same performances.

## Maintenance-free bearings

Each angled arm is fitted with a large maintenance free double ball bearing and 35 mm axle. This high quality bearing is able to carry heavy radial and axial loads. Special protection on the side of the arm is achieved by a special seal of 5 sealing lips and by the joint protecting the bearing. On the other side the disc is protected against dust by an O-ring.

The quality of the bearing and the material used allows a warranty period on the machine for two years. The disc hub is fixed onto the arm by a bolt and special washers that prevent any loosening.



The bolt is protected against soil by its position inside the arm. The CD1000 is as well equipped with maintenance free bearings. The strong 35mm shaft carries 2 rows of ball bear-



ings especially adjusted to face against the high axial and radial loads. The seals have been designed to prevent any deterioration and this is the reason why Kubota covers 2 years of warranty.

# IMPECCABLE CUTTING QUALITY!

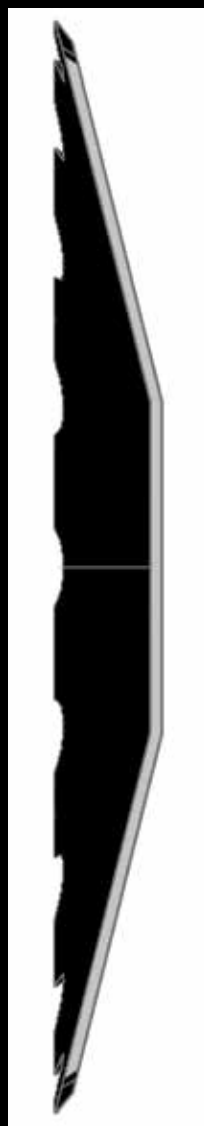
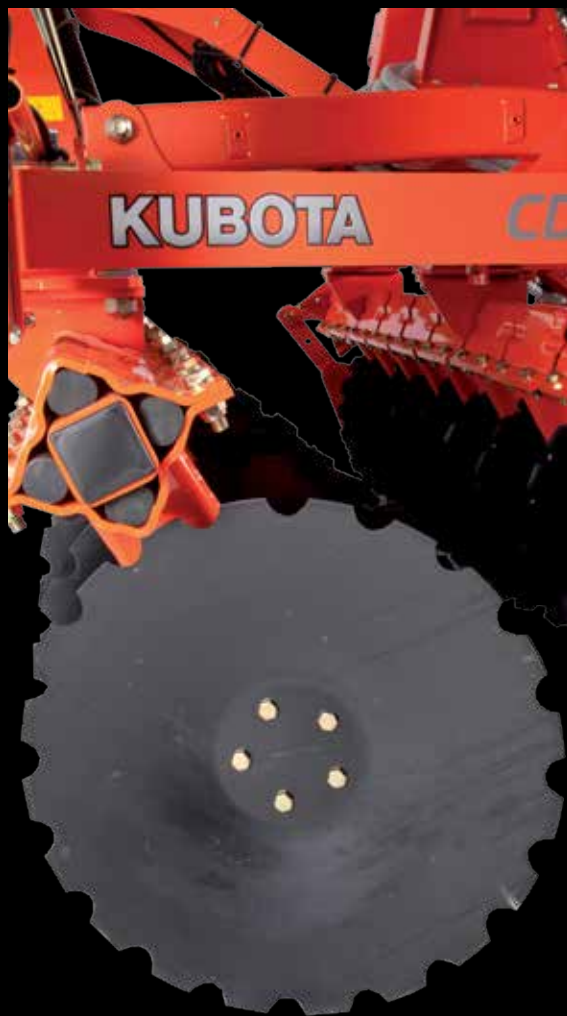

## A large disc diameter

In order to achieve a perfect cutting quality even at a shallow working depth, the CD2000 Series is fitted with a disc of large diameter (600 x 6mm). This increase in diameter allows ease of operation in the highest volumes of vegetable residues, as for example: intermediate crops which have to be destroyed before the seeding of the following crop. The notched discs improve its penetration and rotation irrespective of any plant residues. All CD1000 models get a disc of 520x5mm.

## A constant cutting angle

Irrespective of the diameter of the disc, the cutting angle is always constant due to its conical design.

## Long lasting discs

The discs of 6mm thickness (5 mm for the 520 mm diameter) are given a special heat treatment for a long durability and strength. Thus the machine longevity has been increased and the maintenance costs reduced. Ask for the quality of Kubota!

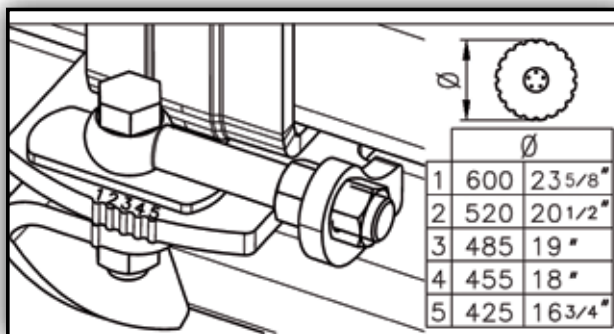

## A lateral adjustment for perfect cutting quality

In order to maintain the optimum cutting quality and to be able to wear the disc as much as possible while maintaining

a perfect cutting quality, the CD2000 Series is fitted with a lateral adjustment which allows the gangs to be positioned correctly as the disc diameter reduces.

A decal on the frame shows the adjustment of the disc sections according to the diameter – simple and efficient! NB: not available on CD1000 series.

# SIMPLE ADJUSTMENTS!



The working depth can be easily adjusted by pivoting spacers, even if it is manually or hydraulically adjusted. At any time during operation the weight of the roller can be used to improve penetration with both systems. With the cylinders locked via a special lock valve, the depth will be constant. With the mechanical adjustment by spacer (only on mounted version), the roller weight is transferred to the machine thanks to a locking bush. In both cases, the roller weight can be used to improve the penetration.



CD1000



## Common equipments for Series CD1000 and CD2000

The adjustable lateral side deflectors on the right and left hand side control the soil flow to provide a perfect level finish. All discs are working at the same depth, even the outer ones



The lateral deflectors are parallelogram-mounted which allows them to follow the ground contours and control the soil flow at the same time. They are equipped with an abutment to limit the working depth especially at the end of the field (whilst reversing).



The following harrow, positioned just in front of the roller, is designed to cut the flow of the soil and to level the soil depending on the aggressiveness selected. The finger harrow bent at the root allows a progressive soil flow without too much power requirement.

# A LARGE CHOICE OF ROLLERS!

According to the soil specifications, the consolidation required, the mixing of the soil and straw, the surface of the soil requested and the lifting capacity available, Kubota offers a choice of rear rollers:

- Cage roller  $\varnothing$  550 mm - 90 kg/m
- Double cage roller  $\varnothing$  400 mm - 160 kg/m (not available on trailed models)
- Actiring roller  $\varnothing$  540 mm - 160 kg/m: active with the adjustable knives, ensuring a good mixture of soil and straw and consolidation.
- Actipack roller  $\varnothing$  560 mm - 220 kg/m: heavier, for clod crushing and very firm recompaction of the soil. Adapted also for heavy and sticky soil conditions.
- Actiflex roller:  $\varnothing$  580 mm - 160 kg/m: Its intensive mixing effect combined with a good recompaction makes this roller the ideal tool for the best volunteer's regrowth. Its large diameter of 580 mm ensures a good driving effect even in light soils. This roller is definitely a good compromise between the weight (160 kg/m) and mixing performances.



220kg/m

Actipack roller  $\varnothing$  560 mm



160kg/m

Actiring roller  $\varnothing$  540 mm



160kg/m

Double cage roller  $\varnothing$  400 mm  
(only for mounted CD's)



90kg/m

Cage roller  $\varnothing$  550 mm



160kg/m

Actiflex roller  $\varnothing$  580 mm

## Load tests

Before the CD1000 and CD2000 Series was launched into the market, they had to pass a whole series of tests to ensure the impeccable quality of the product. It is our major aim to give complete satisfaction to our users:

- The machines are designed by highly qualified engineers with expert knowledge in agricultural engineering.
- Sophisticated technologies are used for each development such as static load test, finite elements method (FEM) and shake-lifetime tests.
- The machines are tested in the field to confirm that the requirements as to functions and strength are met.

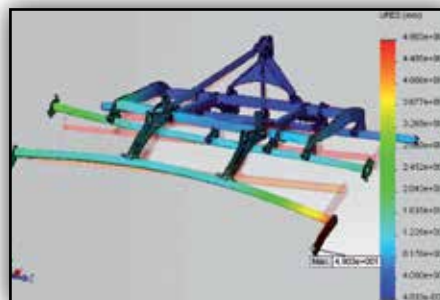

# EXCELLENT PENETRATION CAPACITY



Due to the aggressive discs and the considerable weight (up to 100kg/disc for mounted machines and up to 140 kg for trailed ones), the CD1000 and CD2000 models ensures an excellent working quality even under dry conditions. The ground is completely cut, the stubble abolished and correctly mixed on the surface for a good emergences of weeds and volunteer cereal seeds.



# TECHNICAL SPECIFICATIONS

Specifications	CD1000 series							
Model type	CD1250	CD1300	CD1350	CD1400	CD1400F	CD1500F	CD1400T	CD1500T
Frame type	Rigid				Fold		Fold trailed	
Working width (m)	2.50	3.00	3.50	4.00	4.00	5.00	4.00	5.00
Transport width (m)	2.50	3.00	3.50	4.00	2.45	2.45	2.50	2.50
Disc diameter (mm)	520 x 5 mm (215 kg/mm <sup>2</sup> )							
Number of discs	20	24	28	32	32	40	32	40
Inter row distance (mm)	900							
Frame box section (mm)	100 x 100 x 8				100x100x8 and 200x200x10 (central frame)		100x100x8 and 300x200x10 (central frame)	
Depth control	Mechanical or hydraulic by spacers						Hydraulic by spacers	
Number of double acting valves	1 or 0				2 or 1		3 or 2	
Linkage	Cat. II & Cat. III				Cat. III and Cat. IV		Cat. III or Cat. IV	
Disc spacing (mm)	245				250		250	
Roller equipment	Cage roller ø550mm, Double cage roller ø400mm (not trailed version), Actiring roller ø540mm, Actipack roller ø560mm, Actiflex roller ø580mm							
Weight* with Cage roller (kg)**	1271	1431	1692	1888	2359	2771	3460	3882
Weight* with Actiring/Actiflex roller (kg)**	1445	1646	1947	2265	2625	3119	3726	4230
Weight* with Actipack roller (kg)**	1602	1826	2149	2477	2893	-	3994	4544
HP min. (HP)	55	70	90	110	110	130	130	150
HP max. (HP)	120	150	180	200	200	250	220	260

Specifications	CD2000 series							
Model type	CD2250	CD2300	CD2350	CD2400	CD2400F	CD2500F	CD2400T	CD2500T
Frame	Mounted rigid				Mounted folding		Fold trailed	
Working width (m)	2.50	3.00	3.50	4.00	4.00	5.00	4.00	5.00
Transport width (m)	2.50	3.00	3.50	4.00	2.55	2.55	2.75	2.75
Disc diameter (mm)	600 x 6mm (215 kg/mm <sup>2</sup> )							
Number of discs	20	24	28	32	32	40	32	40
Frame box section (mm)	100 x 100 x 8				100 x 100 x 8 and 200 x 200 x 10 (central frame)		100x100x8 (wing frame sections) and 300x200x10 (central frame)	
Depth control	Mechanical or hydraulic by spacers						Hydraulic by spacers	
Number of double acting valves	1 or 0				2 or 1		3 or 2	
Linkage	Cat. II & Cat. III				Cat. III and Cat. IV		Cat. III or Cat. IV	
Underbeam clearance (mm)	794							
Distance between discs (mm)	245				250		250	
Roller available	Cage roller ø550mm, Double cage roller ø400mm (not trailed version), Actiring roller ø540mm, Actipack roller ø560mm, Actiflex roller ø580mm							
Weight* with Cage roller (kg)**	1467	1739	1944	2158	2718	3166	3876	4336
Weight* with Actiring/Actiflex (kg)**	1641	1954	2199	2535	2984	3514	4142	4698
Weight* with Actipack (kg)**	1796	2134	2401	2747	3252	-	4410	4998
HP min. (HP)	70	90	110	130	150	170	150	170
HP max. (HP)	180	200	220	240	250	300	250	300

\* Weights are given as an indication

\*\* Rigid machines: Mentioned weight are calculated with deflectors, hydraulic depth adjustment and lighting equipment.

Trailed machines: Mentioned weight are calculated with levelling device, deflectors, hydraulic depth adjustment, lighting equipment and front gage wheels.

# STUBBLING AND SEEDING

## *PNEUMATIC SEEDER SH200 OR SH500 INTEGRATED ON CULTIVATOR*



*The position of the distribution outlet is before the roller. Position and angle are adjustable.*



### **Fans adapted to Seeds, Working Speed and Width**

- The SH series can be equipped with two types of fan:
- An electric fan recommended for small seeds and allowing seed rates of 4 kg/min (for a machine 50kg/ha - 4m working width at 12km/h)
- A hydraulic fan for flow rates up to 14 kg/min

# IN ONE PASS



## Seeders for Cover Crops: One Response to the Nitrate Directive

The EU nitrate directive aims to protect water resources so-called vulnerable with a rate higher than 50 mg nitrate/l. One of the measures taken into account to avoid leaching, resulting in the generalization of the soil cover in the fall by vegetation cover, which will absorb nitrogen from the soil and air, to convert it into organic nitrogen. The cover crops will then release nitrogen to the next crop (1/3), protect soil against erosion and improve its structure.

SH200 an SH500 with 200l resp. 500l hopper capacity have been designed to meet a rapid implementation of cover

crop during stubble operations while minimizing their costs. In addition, they can also be used for establishing rape or mix of different diameters seeds (leguminous plant, crucifers, ...).

## Precision and High Work Output

Two models are available depending of the seed rate/ha and the output of the machine: The SH200 will be used for rather small seed sizes with a low seed rate/ha, whereas the SH500 would be preferred with higher seed rate (25 to 50 kg/ha - mix of seeds, grass, etc ...) in order to maintain a significant autonomy even with wide machines. Both models have 8 outputs which will spread the flow of seeds uniformly over the working width.



## Seed Metering Rotors for all Conditions

The SH200 and SH500 are delivered with two types of rotor: one for small seeds (rape, mustard, cabbage, clover, etc ...), and a medium rotor for seeds (vetch, grass, sunflower, ...). The agitator placed above the rotor ensures a steady stream of seeds. A brush, located at the base of the rotor, will regulate the flow and improve the setting accuracy. For large seeds (peas, horse beans, etc ...), it is strongly advised to choose the Flex rotor option, which is able of deforming with large seed diameter.

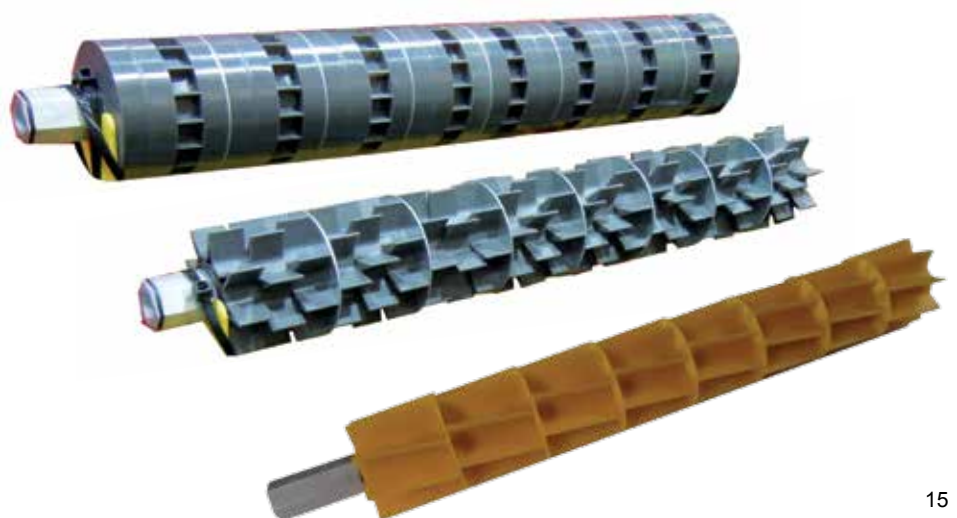

*The company reserves the right to change the above specifications without notice. This brochure is for descriptive purpose only. Some of the items pictured in this brochure are optional and not standard equipment. Please consult your local Kubota dealer for warranty, safety or product information. For your safety, Kubota strongly recommend the use of a seat belt in all applications.*

© 2016 Kverneland Group Les Landes Génusson S.A.S.

---

The Kubota logo is rendered in a teal color. It features a stylized 'K' followed by the letters 'u', 'b', 'o', 't', 'a' in a rounded, sans-serif font.